

Why Water?

Water is far superior to air when it comes to moving heating or cooling through buildings. Here's why.

There are two primary means of conveying heat through a central heating system: air and water. In North America, forced-air heating systems tend to dominate the residential and light commercial systems market. Water-based hydronic systems hold approximately 4 to 5% of the residential market on a national average.

Why such a low percentage of the market for hydronic systems? The most common response from those in the industry is that forced-air systems cost less to install compared to hydronic systems. Another often-cited reason is that forced-air systems can provide both heating and cooling, whereas hydronic systems can only provide heating.

Both of these responses deserve a closer look.

When comparing the cost of a forced-air system to that of a hydronic system, it's important to use an apples-to-apples comparison. For example, the "standard" residential forced-air system is a single-zone system. A single thermostat located somewhere in the house determines when the entire home receives heating or cooling. Upon a call for heating or cooling from this thermostat, the system's blower turns on, and conditioned air is pushed through the entire duct system. How much of the total airflow makes it into each room depends on many factors, such as:

1. Layout and sizing of the duct system.
2. Distance from the air handler to each outlet register.
3. Setting of register dampers.
4. What provisions are made for air to return from each room to the furnace or air handler.

It is possible for a single-zone forced-air system to provide comfort throughout a house. However, this requires the system to be carefully designed and installed. Properly designed duct systems take into account the volume flow rate of air that should be delivered to each room. They should have both trunk and branch ducts that are sized based on these air requirements. Each room should have a properly sized air supply register and a properly sized and located return air grill. Each supply should have an accessible and properly set damper. Finally, the airflow rates to each room should be measured by a trained technician. That technician should also make any necessary damper settings to ensure proper airflow to each room.



Chiller



AirCell



HighWall



ThinWall

While there are systems that meet these criteria, there are also many that do not. The excuses cited for such practice include:

- It's too expensive to install supply and return air ducting to each room.
- There is no reasonable path through which to route the proper supply and return ducting to each room.
- It's easier and cheaper to make a "central" air return and just undercut doors into rooms so that air can exit and flow back to the central return.
- I don't have the instruments to properly balance the forced-air system, and I don't want to pay someone to do this.

Ducting vs. Piping:

Setting aside the reasons based on reducing cost, it is very difficult to install a properly designed sheet metal duct system in a typical wood-framed house, while also concealing the ducting from view. That's because ducting must be much larger than water piping to attain the same rate of heat conveyance.

The reason is a physical property called "heat capacity," which indicates the number of Btus needed to raise one cubic foot (ft³) of a material one degree Fahrenheit (°F). Only 0.018 Btu is required to raise 1 ft³ of air by 1°F. However, approximately 62.4 Btus are required to raise 1 ft³ of water by 1°F.

If one divides the heat capacity of water by that of air (e.g., 62.4/0.018), the ratio is 3,467! This implies that any given volume of water can absorb 3,467 times as much heat as the same volume of air, and the same temperature rise. This gives water an overwhelming advantage as a material for absorbing and conveying heat.

Here's an example: Consider a 3/4" copper tube carrying water at the recommended upper flow rate of 6.5 gallons per minute (gpm). If this water flow passes through a hydronic heating circuit and undergoes a typical 20°F temperature drop from supply to return, it is conveying heat at the following rate:

$$Q = 495 \times gpm \times \Delta T = 495 \times 6.5 \times 20 = 64,350 \frac{\text{Btu}}{\text{hr}}$$

If we wanted to size up a trunk duct to convey the same rate of heat transfer using a standard trunk duct face velocity of 1,000 feet per minute in a system with a typical 40°F temperature drop from supply to return, we could solve for the required cross sectional area of that duct as follows:

$$A = \frac{64,350 \frac{\text{Btu}}{\text{hr}}}{\left(1,000 \frac{\text{ft}}{\text{min}}\right) \left(0.018 \frac{\text{Btu}}{\text{ft}^3 \cdot ^\circ\text{F}}\right) \left(60 \frac{\text{min}}{\text{hr}}\right) (40^\circ\text{F})} = 1.49 \text{ ft}^2$$

If we assumed a rectangular duct with a depth of 10 inches, it would have to be about 21 inches wide to attain the required cross sectional area.

A round duct would have to have a diameter of 16.5 inches to meet this cross sectional area requirement.

Figure 1 shows the 3/4" tube, the 10" x 21" rectangular duct and the 16.5" diameter round duct in scaled proportion.

Figure 1

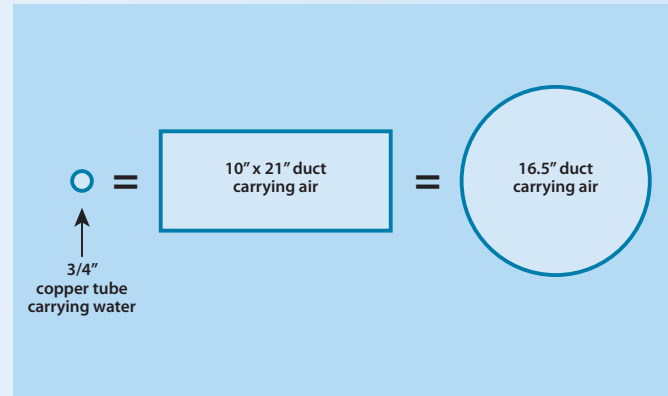

Which of these "conduits" would you rather try to conceal within the cavities of a typical wood-framed building?

If a similar comparison was made assuming 1/2" size flexible tubing carrying water through a hydronic circuit at a maximum flow rate of 2.3 gpm, the equivalent rectangular duct size would be about 6" x 12", and the round equivalent would be 10" diameter ducting.

Figure 2 shows an example of how 1/2" flexible PEX-AL-PEX tubing that is part of a hydronic system is easily routed along and through the 2 x 10 floor framing in a house. The holes near the center height of the floor joist have very little effect on the strength of the joists.

Figure 2



Routing the equivalent 6" x 12" rectangular duct or 10" diameter round duct through this floor framing would be impossible. So, other means of "accommodating" the ducting must be used. Figure 3 shows a soffit being constructed that will eventually "hide" a duct from living space.

Figure 3

Source: <http://angthebuilder.com>

These examples demonstrate that a hydronic system using water to convey heat is far less invasive to a building — both structurally and aesthetically — compared to a properly designed duct system.

Beyond the size difference between hydronic tubing and forced-air ducting of equivalent heat conveying ability is the issue of heat lost. Specifically, the heat loss from tubing or ducting between the mechanical room where the heat is produced and the rooms to which that heat must be delivered.

The 10" x 21" duct from the previous example has about 22 times more surface area than the 3/4" copper tube. If both were assumed to operate at comparable internal temperatures, the rate of heat loss could be estimated as proportional to the ratio of surface area. Thus, the duct loses far more heat than the tube. While one could assume this heat loss is within the thermal envelope (e.g., within heated space) of the building, this is not the case for ducting routed through unheated attics or crawlspaces, which is common practice. An example of such routing is shown in Figure 3A.

Figure 3A

Heat loss may also occur due to poor sealing of joints in ductwork. The differences in heat loss between hydronic tubing and forced-air ducting routed through semiconditioned or unheated spaces could equate to thousands of dollars in added fuel cost over the life of a typical residential heating system.

Distribution Energy:

When considering the energy consumption of a heating system, most people only think about the fuel used to create the heat. Very few ever consider the energy required to move that heat from where it is produced to where it is delivered into occupied space. The energy required to move heat through a building is supplied as electricity to operate one or more circulators in a hydronic system, or one or more blowers/fans in a forced-air system. Here again, well-designed hydronic systems hold a major advantage over their forced-air counterpart.

Figure 4

To demonstrate this, consider the following definition of "distribution efficiency."

$$\text{distribution efficiency} = \frac{\text{rate of heat conveyance at design load}}{\text{power input to distribution equipment}}$$

This ratio simply takes the desired intent of a heating distribution system (e.g., conveyance of heat at a certain maximum rate) and divides it by the necessary electrical power to operate the distribution system. As such, it can be used to compare the relative merit of not only one hydronic system to another, but also to compare hydronic systems to forced-air systems.

Here's an example: Consider an average hydronic system that uses 4 circulators, each operating at 65 watts of electrical power input, to convey a design load of 120,000 Btu/hr. The distribution efficiency of this system would be:

$$\text{distribution efficiency} = \frac{120,000 \text{ Btu/hr}}{4 \times 65 \text{ watts}} = 462 \frac{\text{Btu/hr}}{\text{watt}}$$

This means that each watt of electrical power supplied to this distribution system enables it to deliver 462 Btu/hr of heat to the building.

By itself, this number has little meaning. However, the relative merit of this system can be judged by comparing its distribution efficiency to that of other systems.

Here's another example: Consider a forced-air furnace with a standard blower motor that delivers 85,000 Btu/hr to a house, while its blower operates at 750 watts electrical power input. The distribution efficiency of this forced-air system is:

$$\text{distribution efficiency} = \frac{85,000 \text{ Btu/hr}}{750 \text{ watts}} = 113 \frac{\text{Btu/hr}}{\text{watt}}$$

This means that each watt of electrical power input to the blower of the forced-air system only enabled it to deliver 113 Btu/hr to the building. This is less than 1/4 the distribution efficiency of the previously cited hydronic system. It means that the hydronic system was able to deliver heat to the building using less than 25% of the electrical energy of the forced-air system.

With good design and modern hardware, the distribution efficiency of hydronic heating systems is often 10 times higher than that of forced-air systems. Hydronic heating systems with distribution efficiencies of over 3,000 Btu/hr/watt have already been created through careful design and component selection.

Over the life of a building, the operating cost of a residential size hydronic system could be several thousands of dollars less than a forced-air system due to significantly lower electrical energy use by the distribution system. This is a decisive advantage of hydronic heating that should be discussed with potential clients weighing the merits of hydronic versus forced-air systems.

Here's another example: Consider a well-designed hydronic distribution system that supplies a 50,000 Btu/hr design heating load using a single circulator operating on 65 watts. Assume that the equivalent forced-air system would require a blower operating on 500 watts. If both the circulator and blower operated for 3,500 hours per year in a house where the local cost of electricity of \$0.14/kwhr, the annual difference in operating cost would be:

$$\Delta \text{cost} = (500 - 65 \text{ watts}) \left(3500 \frac{\text{hr}}{\text{yr}} \right) \left(\frac{1 \text{ kw}}{1000 \text{ watt}} \right) \left(\frac{\$0.14}{\text{kwhr}} \right) = \$182.70/\text{yr}$$

After only 10 years, with an assumed 4% per year escalation in electrical energy cost, the total operating cost of this forced-air system would be \$2,193 higher than the total operating cost of the assumed hydronic system. This may be more than the homeowner pays for a year's worth of heating fuel. The larger the system, the larger the difference in operating cost is likely to be.

Ability to Zone:

The purpose of any heating system is to provide comfort in all areas of a building throughout the heating season. Doing so requires systems that can adapt to the lifestyle of the building occupants, as well as the constantly changing thermal conditions inside and outside of a building.

One person might prefer sleeping in a room maintained at 63°F, while another feels chilled if their bedroom is anything less than 72°F. One occupant might prefer a living room maintained at 70°F while relaxed and reading, while another wants the temperature in the exercise room at 65°F during a workout.

The combination of room thermal characteristics, outdoor conditions and occupant expectations presents a complex and dynamic challenge for the building's heating system as it attempts to maintain comfort.

One method that has long been used to help meet this challenge is dividing the building's heating system into zones. A zone is any area of a building for which indoor air temperature is controlled by a single thermostat (or other temperature-sensing device). A zone can be as small as a single room, or it may be as large as an entire building.

Figure 5 shows a zoning plan for the first floor of a house. The living room, kitchen, halfbath and laundry are combined into a single zone. The master bedroom, master bathroom and closet form another zone. The garage is also treated as a separate zone.

Figure 5

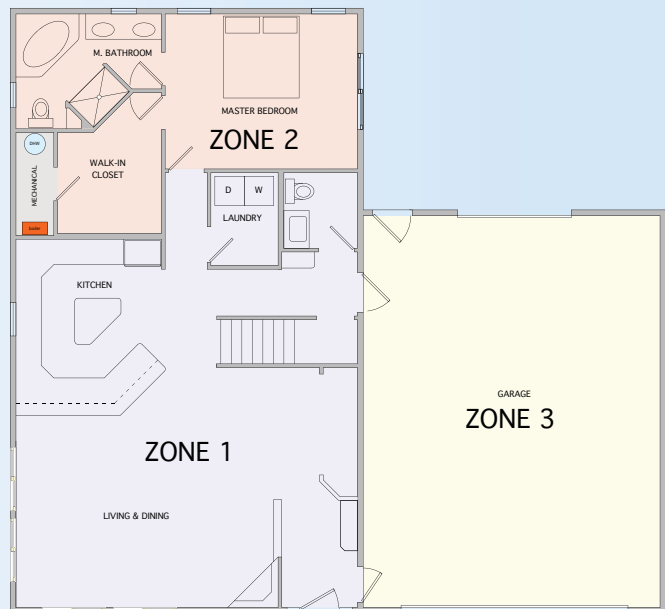

Proper zoning accounts for differences in the activities that occur in different areas of a building, as well as differences in preferred comfort levels, interior heat gain and the desire to reduce energy use through reduced temperature settings (e.g., "setback").

There are several straightforward ways to create zoned hydronic heating and cooling systems. All of these approaches are simpler and less expensive than equivalent zoning techniques for forced-air systems.

But What About Cooling?

One myth that has existed in the residential HVAC industry is that hydronic systems are only suitable for heating. This is based on the premise that ducting systems can convey either heated or cooled air, but piping is only good for conveying heated water. This is simply not true.

The same physical properties that make water ideal for conveying heat also make it ideal for conveying cooling. Cooling is just the removal of heat. We've already seen that one cubic foot of water can absorb 3,467 times as much heat as a cubic foot of air for the same temperature change. This implies that chilled water circulated through some type of "terminal unit" is ideal for absorbing heat from occupied space. It can do this using tubing that is much smaller than equivalent ducting.

Engineers who design commercial, industrial and institutional buildings have long understood the benefits of chilled-water cooling systems in comparison to "all-air" systems. Many large buildings contain a central plant in which refrigeration equipment known as chillers reduce the temperature of water into the range of 40° to 50°F. This water is then circulated through insulated piping to all areas of the building, where it eventually passes through various terminal units to absorb sensible heat and condense water vapor from the building's air.

One of the most common types of chilled-water terminal units is known as an air handler. It contains a "coil" made of copper tubing and aluminum fins, as well as a blower. Chilled water passes through the copper tubing and cools the attached aluminum fins. The blower forces air through the spaces between these fins and tubes. The air emerges from the downstream side of the coil at a lower temperature and reduced relative humidity. Figure 6 shows an example of a smaller horizontal fan-coil. Figure 7 shows its schematic representation and internal construction.

Figure 6



Figure 7

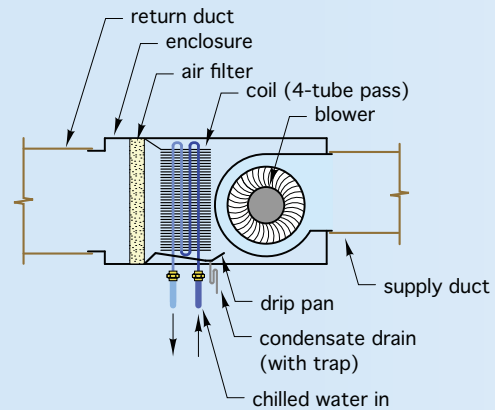

Notice that figure 7 shows a "drip pan" under the coil. This component captures water droplets that drip from the coil as the air passing through it is dehumidified. On a humid day, even a small air handler can produce several gallons of condensate. This water must be routed out of the air handler to some type of drain. The small white pipe seen at the lower right corner of the air handler in Figure 6 is the condensate drain.

Multiple air handlers can be set up to create a zoned hydronic cooling system, as shown in Figure 8.

Figure 8

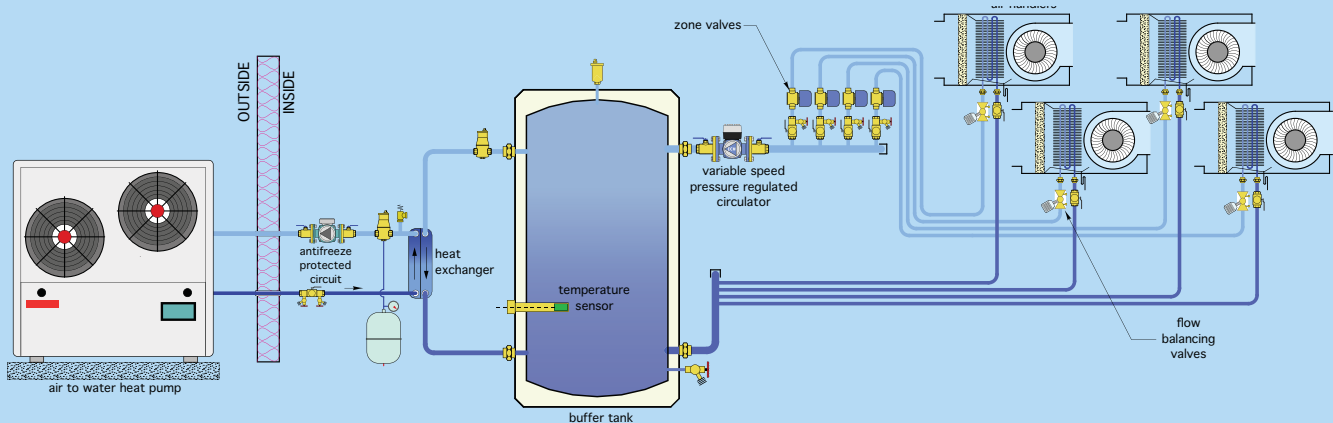

In this system, an air-to-water heat pump located outside the building creates the cooling effect. It chills an antifreeze solution that circulates between the heat pump and a stainless steel heat exchanger located within the mechanical room. The antifreeze solution protects the heat pump and exterior piping from possible freeze damage during winter. The chilled antifreeze absorbs heat from water that is circulated from the upper portion of the buffer tank, through the heat exchanger, and back into the lower portion of the tank. The buffer tank allows the cooling capacity of the heat pump to be different from the current cooling needs of the chilled-water distribution system. This prevents the heat pump from operating with short cycles during partial load conditions.

Each chilled-water air handler operates independently to meet the cooling requirements of its associated zone. Flow through each air handler is controlled by a zone valve. A variable-speed circulator with a high-efficiency motor adjusts the flow rate through the distribution system based on the number of air handlers that are currently operating.

This type of circulator minimizes electrical energy use, which in turn reduces the cooling load on the system.

Systems based on the principles shown in Figure 8 could supply fewer zones or more zones. They can also be configured to supply heating through the air handlers during colder weather. In this case, the heat pump heats the water in the buffer tank.

It's also possible to use chilled water for radiant cooling. The chilled water is circulated through tubing embedded in floors, ceilings or walls. The water absorbs heat from those surfaces without causing condensation to form on them. This requires controls that monitor both the temperature and relative humidity of the space being cooled and adjust the temperature of the chilled water to prevent condensation on cooled surfaces.

Radiant cooling uses significantly less distribution energy compared to systems that deliver all the cooling capacity using forced air. This is again based on the ability of water to absorb and convey heat using a tiny fraction of the flow rate required by an equivalent forced-air system.

Figure 9 shows the use of a 3-way motorized mixing valve operated by a dewpoint controller to maintain the proper chilled-water supply temperature to a manifold station supplying several radiant panel circuits.

Figure 9

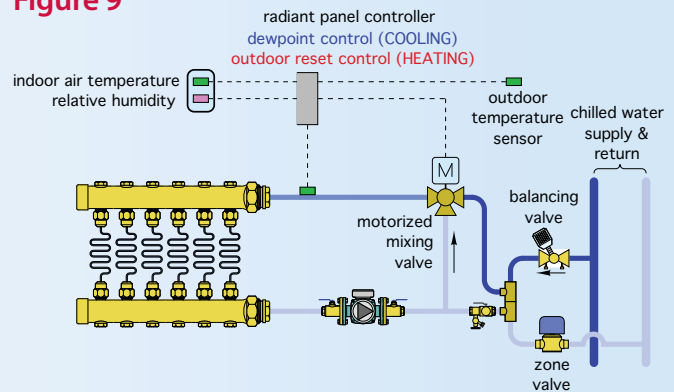

The component arrangement for controlling chilled-water flow through the radiant panel is identical to that used to manage warm water flow through the radiant panel for heating. The only difference is the control logic used to operate the motorized mixing valve. Thus, the radiant panel can provide both heating and cooling.

Radiant cooling, however, is limited to sensible cooling (e.g., cooling the air without removing moisture from it). Sensible cooling alone is not sufficient to maintain comfortable interior conditions, especially on humid days. To deal with this, nearly all radiant cooling systems include a chilled-water air handler that operates at chilled-water temperatures low enough to remove sufficient moisture from the air for comfortable humidity levels. The condensed water is collected by a drip pan in this air handler and routed to a drain. The flow rate of chilled water through the air handler's coil can be automatically regulated to maintain a given interior relative humidity.

The same air handler that removes moisture during cooling can sometimes be used to circulate ventilation air to the space. This concept is shown in Figure 10.

Figure 10

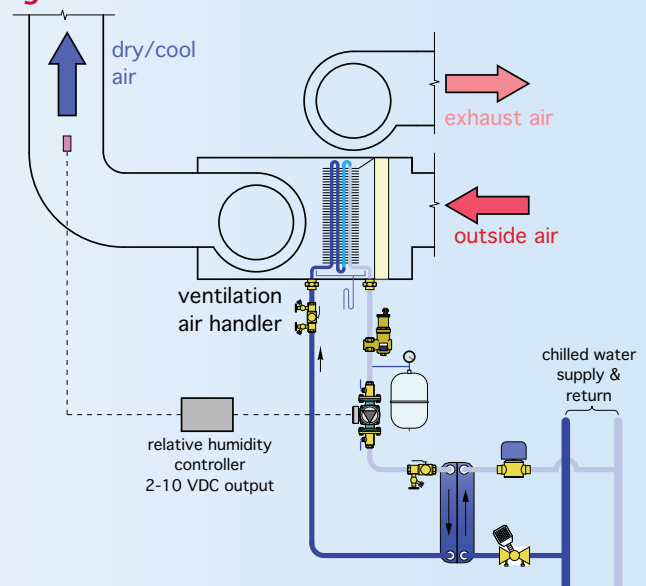

Notice that the coil circuit is set up to operate with an antifreeze solution to protect it during winter when incoming ventilation air may be below freezing. The antifreeze solution circulates between the air handler's coil and the stainless steel plate heat exchanger. During cooling operation, the antifreeze is cooled by chilled water passing through the other side of the heat exchanger.

In systems requiring more than 5 tons of peak cooling capacity, it is possible to use multiple air-to-water heat pumps as staged chillers. On mild days, only one chiller needs to operate, but on hot, humid days, automatic controls turn on additional chillers to create the necessary cooling capacity. Figure 11 shows an example of multiple air-to-water heat pumps that can be used as staged chillers during cooling mode operation.

Figure 11

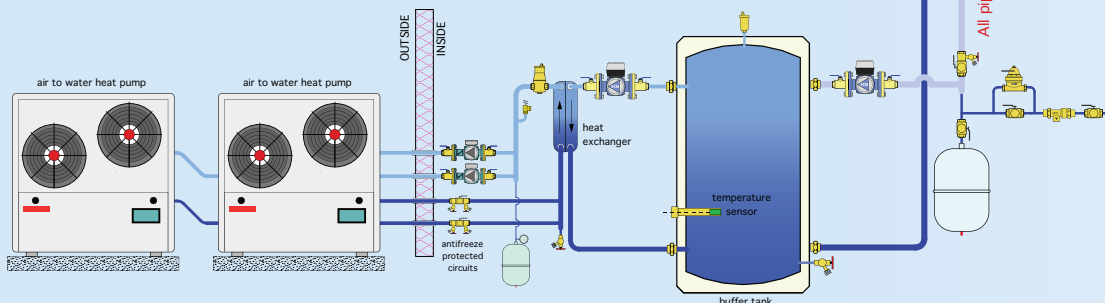
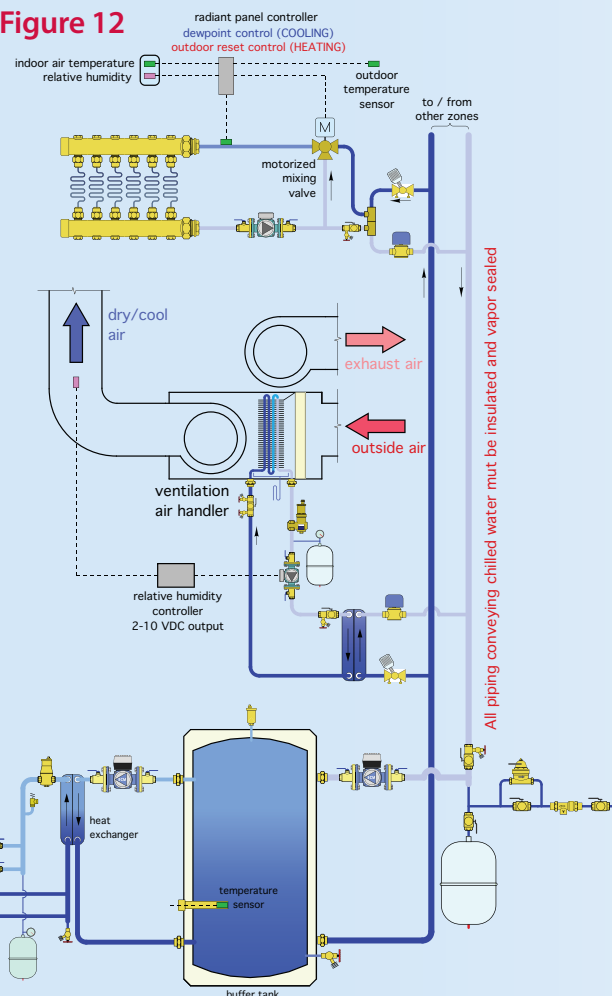

Figure 12 shows how several of the subsystems described in earlier paragraphs can be combined to create a complete chilled-water heating/cooling/ventilation system. This system uses radiant panels for sensible cooling, and an air handler for moisture removal and conveyance of ventilation air. The same radiant panel is used for heating during cold weather. Two air-to-water heat pumps serve as chillers during the cooling season and heat sources during cold weather. When operating in cooling mode, both chillers chill the water in the buffer tank. This water is then supplied by a variable-speed circulator to the radiant cooling subsystem and the air handler.

Figure 12



Summary

- Water is a superior material for moving heat as well as cooling effect through a wide range of buildings.
- The size of the required piping is very small in comparison to ducting of equivalent heat conveyance ability. This makes a hydronic system much less invasive to install in both new and retrofit applications.
- The electrical power required by circulators to move water through a hydronic system is typically a fraction of that required by blowers of comparable heat conveyance capacity. This can save thousands of dollars in electrical cost over the life of the distribution system.
- A wide variety of equipment is now available to create efficient and effective chilled water cooling systems for residential and light commercial buildings.
- Air-to-water heat pumps can provide warm water for hydronic heating, as well as chilled water for hydronic cooling.



SPACE PAK 
HYDRONICS

www.spacepak.com